

PHYSICS 160  
MAKE UP EXAM 4 - GREEN  
SPRING 2012

Please re-do *all* questions you missed on the original exam. (Any questions not re-done will be given zero points.) For full credit, you must show all steps of your work, and questions will be awarded partial credit based on level of completeness and comprehensibility. Corrections are due at the beginning of lecture on Friday, April 13!

The answers to the original exam are:

1. (c) 2. (d) 3. (a)

4. (d) 5. (a) 6. (c)

7. (b)

1. A roller coaster starts from rest at point  $A$  where the height  $h = 25\text{ m}$ . It slides along the track without friction. What is the normal force acting on a  $75\text{ kg}$  rider of the roller coaster at the top of the loop-to-loop (point  $B$ )? As shown, the radius of the loop-to-loop's circle is  $7.5\text{ m}$ .

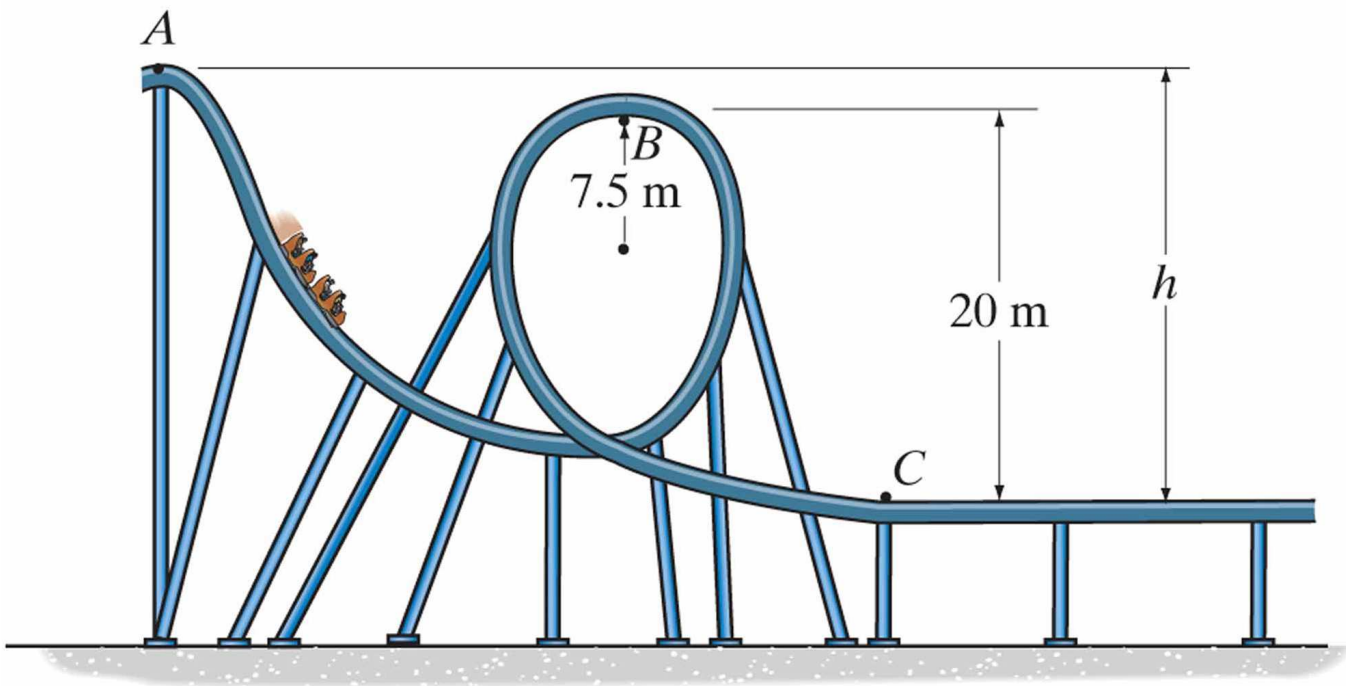

2. A  $1.65\text{-m}$  long pendulum is started from the vertical position by giving it a speed of  $0.900\text{ m/s}$ . To what maximum angle  $\theta$  (from the vertical) will the pendulum go before turning around?

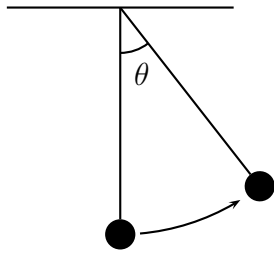

3. A  $5.00\text{ kg}$  mass with  $\vec{v}_{A1} = 3.00\text{ m/s}$  at  $25.0^\circ$  has an elastic collision with a  $12.5\text{ kg}$  mass with  $\vec{v}_{B1} = 6.00\text{ m/s}$  at  $165^\circ$ . If the  $5.00\text{ kg}$  mass bounces with  $\vec{v}_{A2} = 9.53\text{ m/s}$  at  $172^\circ$ , with what speed does the  $12.5\text{ kg}$  mass bounce? All angles are from the positive  $x$ -axis.

4. A boy rides a sled down an icy (and therefore frictionless) hill whose height above the ground is given by the equation  $y = x^{3/2}$ , where  $y$  is in meters when  $x$  is in meters. If he starts from rest at  $x = 3.5$  m, how fast will he be going at the bottom?

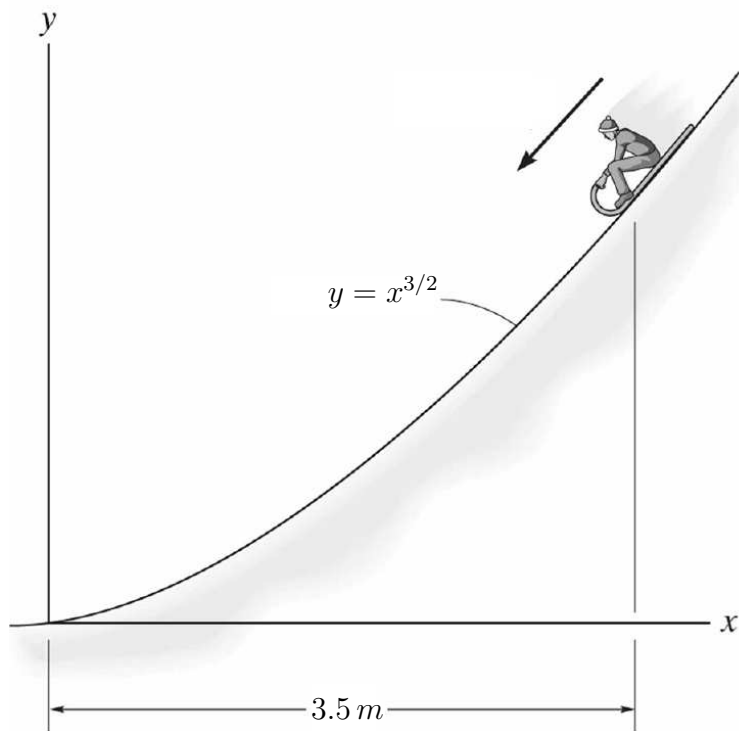

5. A  $5.0\text{-kg}$  ball going  $6.0\text{ m/s}$  at  $-35^\circ$  hits the ground and bounces at  $5.3\text{ m/s}$  at  $+43^\circ$  (both angles are from the positive  $x$ -axis). If during its bounce, the average force on the ball has a  $y$ -component  $F_{av,y} = 2350\text{ N}$ , how long was the bounce time?

6. A  $6\text{ kg}$  collar is allowed to slide over a frictionless pole whose height above the ground obeys the parabolic equation  $y = 8 - (1/2)x^2$ , where  $y$  is in meters when  $x$  is in meters. Attached to the collar is a  $k = 30\text{ N/m}$  spring. The spring, unstretched length  $1\text{ m}$ , is connected such that as the collar moves, the spring is always oriented along the line connecting the point  $O$  and the collar. If the collar is started from rest at  $x = 0$ , which of the following graphs correctly displays the collar's total energy,  $E$ , versus position,  $x$  as it slides down the pole? *Justify your answer in words!*

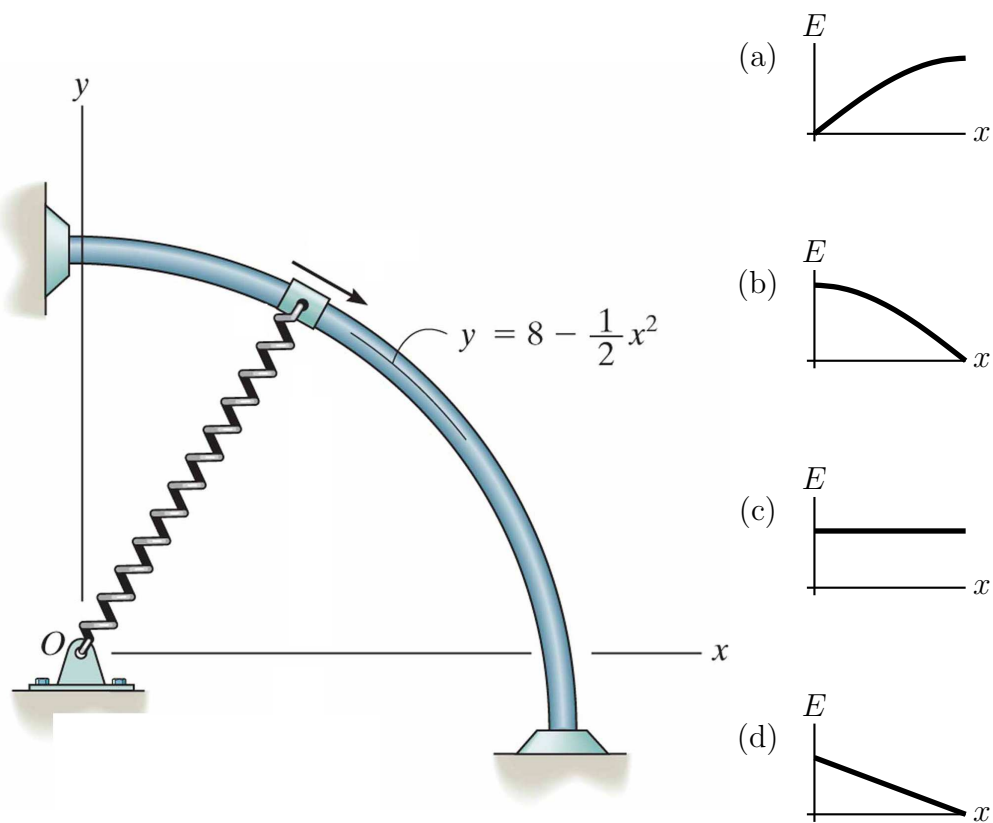

7. A  $12.0\text{ kg}$  mass slides  $10.0\text{ m}$  down a  $30^\circ$  incline starting with a speed of  $5.85\text{ m/s}$  before hitting a  $424\text{ N/m}$  spring. If the coefficient of kinetic friction between the mass and the incline is  $\mu_k = 0.350$ , what *additional* distance,  $x$ , does the mass travel before stopping?

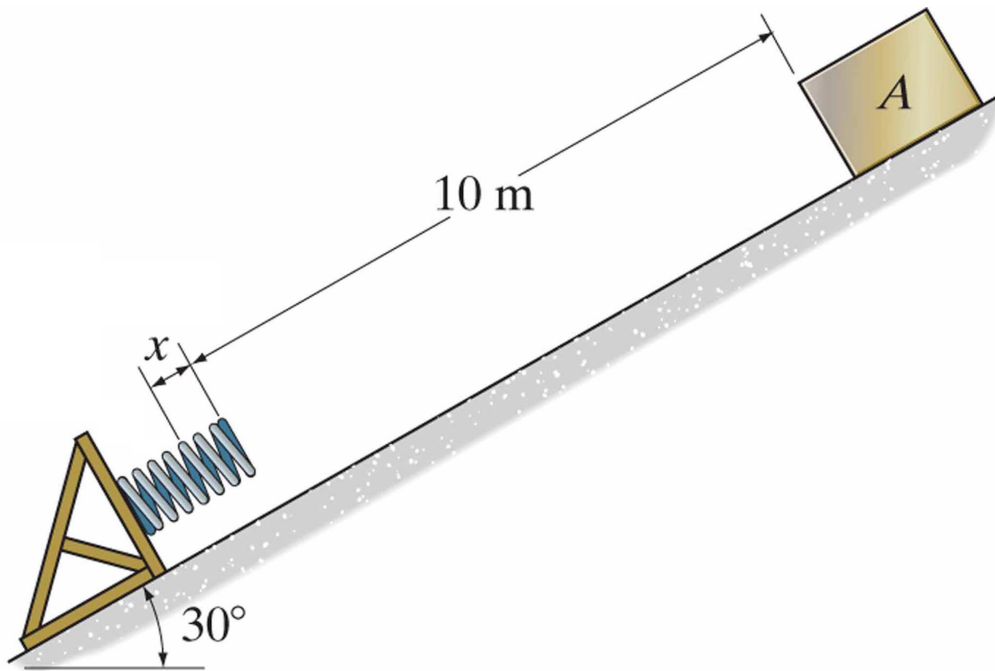



8. One day while driving your  $M_A = 2000 \text{ kg}$  car while going Northeast you, very embarrassingly, smash into your instructor's  $M_B = 1500 \text{ kg}$  car which was going due West. If the cars have a completely inelastic collision and just after the collision are going  $12 \text{ m/s}$  at  $30^\circ$  East of North, how fast was each car going before the collision?

