

(1.) What is the magnitude and direction of the vector sum for the two force vectors shown.

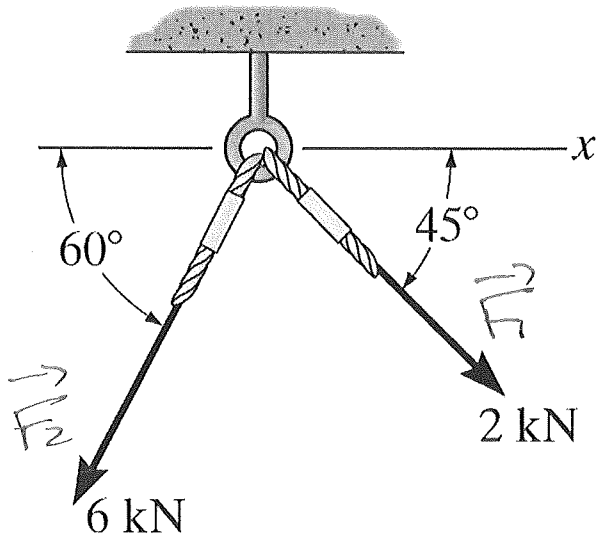

$$\sum F_x = F_{1,x} + F_{2,x}, \quad \sum F_y = F_{1,y} + F_{2,y}$$

$$F_{1,x} = +F_1 \cos 45^\circ$$

$$F_{1,y} = -F_1 \sin 45^\circ$$

$$F_{2,x} = -F_2 \cos 60^\circ$$

$$F_{2,y} = -F_2 \sin 60^\circ$$

$$\sum F_x = 2 \text{ kN} \cos 45^\circ - 6 \text{ kN} \cos 60^\circ = -1.586 \text{ kN}$$

$$\sum F_y = -2 \text{ kN} \sin 45^\circ - 6 \text{ kN} \sin 60^\circ = -6.61 \text{ kN}$$

$$\sum F = \sqrt{(1.586 \text{ kN})^2 + (6.61 \text{ kN})^2} = 6.798 \text{ kN} = 6.8 \text{ kN}$$

$$\theta = \tan^{-1} \left(\frac{6.61}{1.586} \right) = 76.5^\circ$$

(a)	
(b)	
(c)	
(d)	

(2.) A projectile is launched at 37° above the horizontal from the top of the cliff with a speed of 25 m/s . If its range is 71.5 m , how high above the ground is the cliff?

8.96 m (a) 9.0 m
(b) 11.2 m
(c) 15.9 m
(d) 24.9 m
(e) 31.5 m

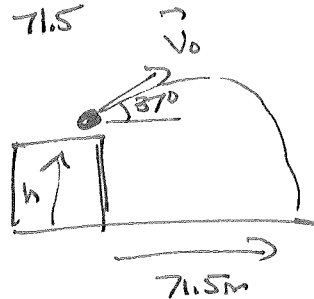

Known: $x_0 = 0, X = 71.5 \text{ m}, y = 0$

$$V_{0,x} = V_0 \cos \alpha = 25 \text{ m/s} \cos 37^\circ$$

$$V_{0,y} = V_0 \sin \alpha = 25 \text{ m/s} \sin 37^\circ$$

Unknown: $y_0 = h = ?, t, V_y$

So use $X = X_0 + V_{0,x} t$ to find t

then $y = y_0 + V_{0,y} t - \frac{1}{2} g t^2$ to find h

$$X = X_0 + V_{0,x} t \Rightarrow 71.5 \text{ m} = 25 \text{ m/s} \cos 37^\circ t \Rightarrow t = \frac{71.5 \text{ m}}{25 \text{ m/s} \cos 37^\circ} = 3.581 \text{ s}$$

$$y = y_0 + V_{0,y} t - \frac{1}{2} g t^2 \Rightarrow 0 = h + 25 \text{ m/s} \sin 37^\circ (3.581 \text{ s}) - \frac{1}{2} (9.8 \text{ m/s}^2) (3.581 \text{ s})^2$$

$$\Rightarrow 0 = h + \overset{53.80 \text{ m}}{53.80 \text{ m}} - 62.84 \text{ m} \Rightarrow 0 = h - 8.96 \text{ m}$$

$$\Rightarrow h = 8.96 \text{ m} = \text{Answer}$$

(3.) By pulling on the 25-kg crate as shown, the man is able to drag it horizontally across the floor. Which of the following is a true statement about the crate?

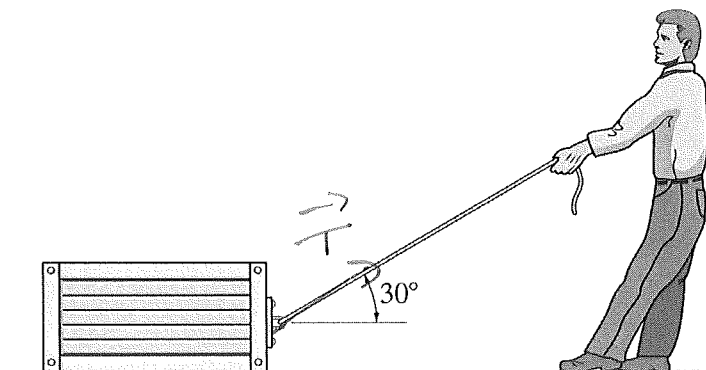

(a) The normal force acting on the crate is equal to 245 N.

(b) The normal force acting on the crate is smaller than 245 N.

(c) The normal force acting on the crate is greater than 245 N.

(d) There is not enough information to make a statement about the magnitude of the normal force as compared to 245 N.

Forces: \vec{n} up, \vec{w} down, \vec{T} at 30°
 Maybe friction, \vec{f}_k to left

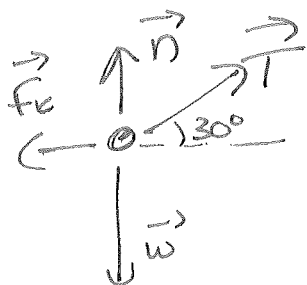

No motion in y-DIRECTION $\Rightarrow \sum F_y = 0$

$$\Rightarrow n_y + T_y + w_y + f_{ky} = 0$$

$$\Rightarrow n + T \sin 30^\circ - w = 0 \Rightarrow n = w - \frac{1}{2}T$$

$$w = 25 \text{ kg} (9.8 \text{ m/s}^2) = 245 \text{ N} \Rightarrow n = 245 \text{ N} - \frac{1}{2}T$$

So normal must be smaller than 245 N

- (4.) A 65 kg man riding in an elevator has an apparent weight of 715 N, what is the elevator's acceleration?

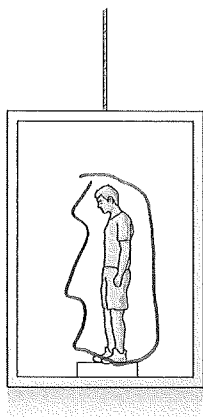

(a) 1.2 m/s^2 , upward
(b) 1.2 m/s^2 , downward
(c) 9.8 m/s^2 , downward
(d) 11.0 m/s^2 , upward
(e) 11.0 m/s^2 , downward

Forces on MAN: \vec{n} up

$$n = 715 \text{ N}$$

$$\vec{w} \text{ DOWN, } w = mg = (65 \text{ kg})(9.8 \text{ m/s}^2) = 637 \text{ N}$$



$$\sum F_y = ma_y \Rightarrow n - w = ma_y$$

$$\Rightarrow 715 \text{ N} - 637 \text{ N} = 65 \text{ kg } a_y$$

$$\Rightarrow 78 \text{ N} = 65 \text{ kg } a_y$$

$$\Rightarrow a_y = \frac{78 \text{ N}}{65 \text{ kg}} = +1.2 \text{ m/s}^2 = 1.2 \text{ m/s}^2 \text{ up}$$

- (5.) A boy rides a sled down an icy (and therefore frictionless) hill whose height above the ground is given by the equation $y = x^{3/4}$, where y is in meters when x is in meters. If he starts from rest at $x = 1.5 \text{ m}$, how fast will he be going at the bottom?

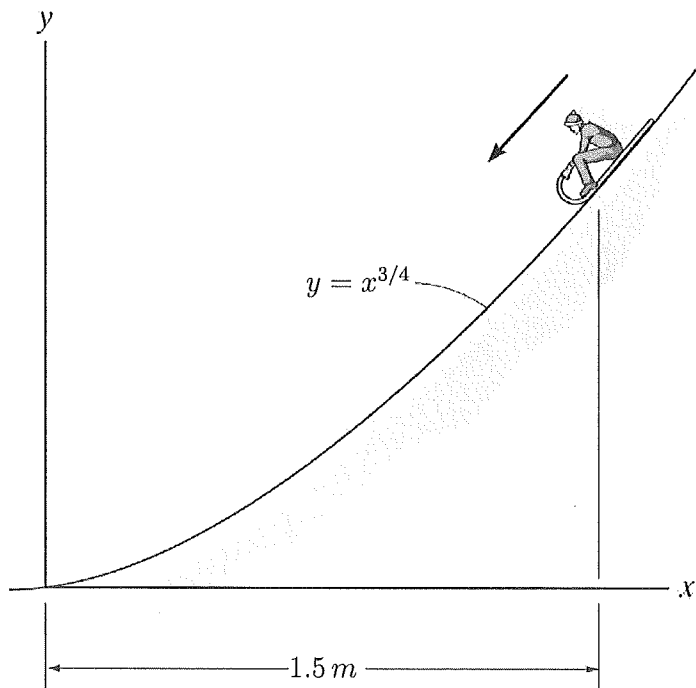

(a) 5.15 m/s

(b) 5.42 m/s

(c) 6.00 m/s

(d) 7.35 m/s

(e) There is not enough information to determine.

Gravity only force doing work \Rightarrow

$$\frac{1}{2}mv_1^2 + mgy_1 = \frac{1}{2}mv_2^2 + mgy_2$$

$$v_1 = 0, \quad y_1 = (1.5)^{3/4} = 1.3554 \text{ m}, \quad v_2 = ?, \quad y_2 = 0$$

$$\Rightarrow gy_1 = \frac{1}{2}v_2^2 \Rightarrow v_2 = \sqrt{2gy_1} = \sqrt{2(9.8 \text{ m/s}^2)(1.3554 \text{ m})}$$

$$= \sqrt{2(6.556 \text{ m}^2/\text{s}^2)} = 5.15 \text{ m/s}$$

- (6.) A 12.5-kg mass is sliding across a frictionless floor until it stopped by a 1000 N/m spring (which is initially uncompressed). If the maximum compression of the spring is 0.15 m, how fast was the mass originally going?

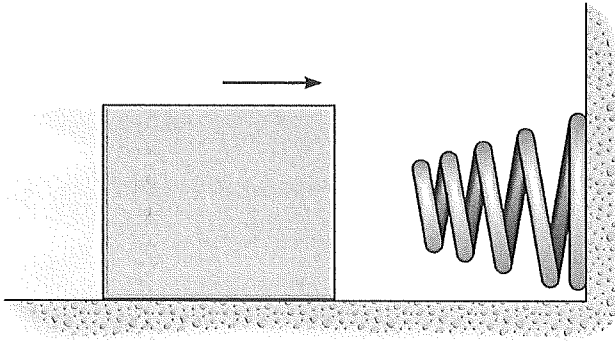

(a) 1.16 m/s
(b) 1.8 m/s
(c) 1.64 m/s
(d) <u>1.34</u> m/s
(e) 2.46 m/s

Spring only force doing work:

$$\frac{1}{2} m v_1^2 + \frac{1}{2} k s_1^2 = \frac{1}{2} m v_2^2 + \frac{1}{2} k s_2^2$$

$$v_1 = ?, s_1 = 0, v_2 = 0, s_2 = 0.15 \text{ m}$$

$$\Rightarrow \frac{1}{2} (12.5 \text{ kg}) (v_1^2) = \frac{1}{2} (1000 \text{ N/m}) (0.15 \text{ m})^2$$

$$\Rightarrow v_1 = \sqrt{\frac{(1000 \text{ N/m}) (0.15 \text{ m})^2}{12.5 \text{ kg}}} = \sqrt{1.8 \text{ m}^2/\text{s}^2} = 1.34 \text{ m/s}$$

- (7.) A 2000-kg tanker car going 5 m/s to the right has a completely inelastic collision with a 1500-kg boxcar going to the left. If the combination is going 1 m/s to the left after the collision, how fast was the boxcar going before?

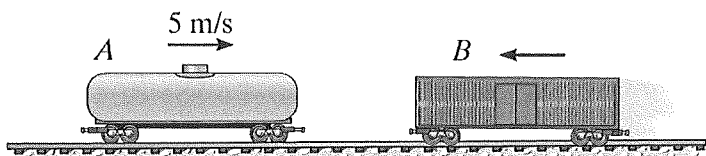

(a) 4.33 m/s

(b) 5.56 m/s

(c) 9.00 m/s

(d) 10.6 m/s

(e) 13.0 m/s

Conservation of Momentum:

$$M_A V_{A,x} + M_B V_{B,x} = (M_A + M_B) V_{2,x}$$

$$V_{A,x} = 5 \text{ m/s}, \quad V_{B,x} = ?, \quad V_{2,x} = -1 \text{ m/s}$$

↑
left

$$\Rightarrow 2000 \text{ kg} (5 \text{ m/s}) + 1500 \text{ kg} V_{B,x} = (3500 \text{ kg}) (-1 \text{ m/s})$$

$$\Rightarrow 10000 \text{ kg}\cdot\text{m/s} + 1500 \text{ kg} V_{B,x} = -3500 \text{ kg}\cdot\text{m/s}$$

$$\Rightarrow 1500 \text{ kg} V_{B,x} = -3500 \text{ kg}\cdot\text{m/s} - 10000 \text{ kg}\cdot\text{m/s} = -13500 \text{ kg}\cdot\text{m/s}$$

$$\Rightarrow V_{B,x} = \frac{-13500 \text{ kg}\cdot\text{m/s}}{1500 \text{ kg}} = -9 \text{ m/s} = 9 \text{ m/s to left}$$

(8.) A point 0.75 m from the center of a spinning wheel has a linear speed of 1.5 m/s . What is the angular speed of the wheel in *RPM*?

- | |
|------------------------|
| (a) 0.209 RPM |
| (b) 0.5 RPM |
| (c) 2 RPM |
| (d) 4.77 RPM |
| (e) 19.1 RPM |

$$V = \omega r \Rightarrow \omega = \frac{V}{r} = \frac{1.5 \text{ m/s}}{0.75 \text{ m}} = 2/\text{s}$$

$$\Rightarrow \omega = 2 \frac{\text{rad}}{\text{s}} \times \frac{1 \text{ rev}}{2\pi \text{ rad}} \times \frac{60 \text{ s}}{1 \text{ min}}$$

$$= 19.1 \text{ RPM}$$

- (9.) A uniform bar is leaning at rest against a wall as shown. If the normal force acting on the bar at point A is 25 N, what is the weight of the bar? Assume there is no friction between the bar and the wall at point A.

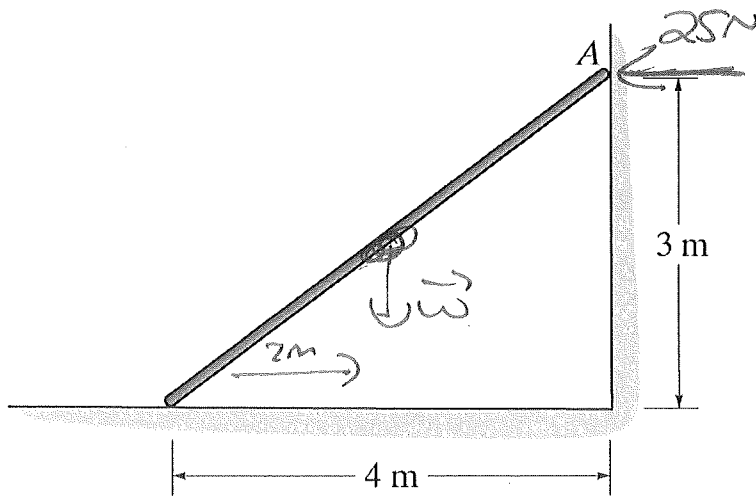

(a) 16.7 N
(b) 18.75 N
(c) 25 N
(d) 37.5 N
(e) 75 N

Uniform Bar $\Rightarrow \vec{W}$ in middle $\Rightarrow 2m$ from end horizontally

No Rotation $\Rightarrow \sum \tau = 0$

\vec{W} tries to rotate clockwise while \vec{n} counterclockwise

$$\Rightarrow \sum \tau = \tau_n - \tau_w \Rightarrow \tau_w = \tau_n$$

\vec{W} vertical, \vec{n} horizontal $\Rightarrow xW = yn$

$$\Rightarrow (2m)W = (3m)(25N) \Rightarrow W = (25N)\left(\frac{3}{2}\right) = 37.5N$$

(10.) A man, sitting on the office chair shown, has two large weights in his hands. The man is spinning at 3 rad/s with the weights held out to the sides. Which of the following is a possible angular speed for the man after he has pulled the weights closely to his chest?

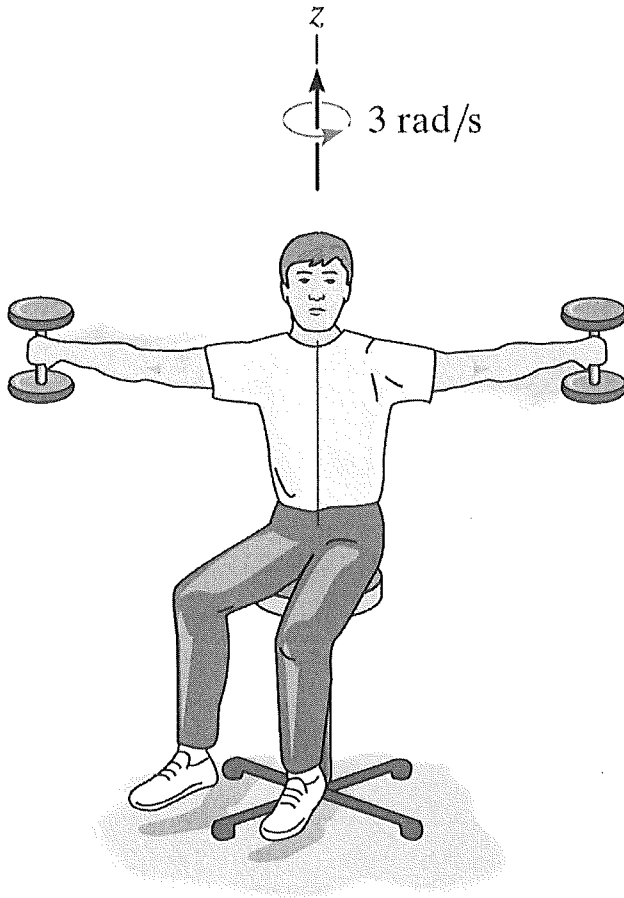

- | |
|-----------------------|
| (a) 0 rad/s |
| (b) 2 rad/s |
| (c) 3 rad/s |
| (d) 4 rad/s |

Conservation of Angular
Momentum with single object

$$\Rightarrow I_1 \omega_1 = I_2 \omega_2$$

$\omega_1 = 3 \text{ rad/s}$. BRINGING WEIGHTS IN \Rightarrow

$$I_2 < I_1 \quad \text{so } \omega_2 > \omega_1$$

- (11.) A 3 kg mass is attached to a 250 N/m spring as shown below. At time $t = 0$, the mass is started from rest some distance from its equilibrium position. Where should the mass be started to give its motion a period of 1.3 s? Assume there is no friction between the mass and the floor.

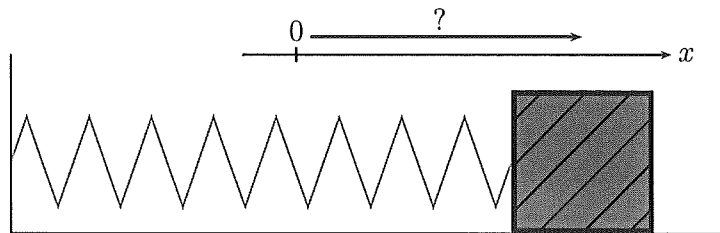

(a)	0.69 m
(b)	0.765 m
(c)	1.3 m
(d)	Any distance will give a period of 1.3 s.
(e)	There is no distance that will give a period of 1.3 s.

$$\omega = \sqrt{\frac{k}{m}} = \sqrt{\frac{250 \text{ N/m}}{3 \text{ kg}}} = 9.1287 \text{ rad/s}$$

$$\omega = \frac{2\pi}{T} \Rightarrow T = \frac{2\pi}{\omega} = \frac{2\pi \text{ rad}}{9.1287 \text{ rad/s}} = 0.688 \text{ s}$$

So Period is fixed at 0.688 s and no choice for

initial position can change it.

- (12.) A 2 kg mass is attached to a 50 N/m spring as shown below. At time $t = 0$, the mass is started from its equilibrium position with a velocity of 4.6 m/s to the right. There is no friction between the mass and the floor. What is the phase angle, ϕ , in the equation $x = A \cos(\omega t + \phi)$ for this motion? (Assume to right is positive.)

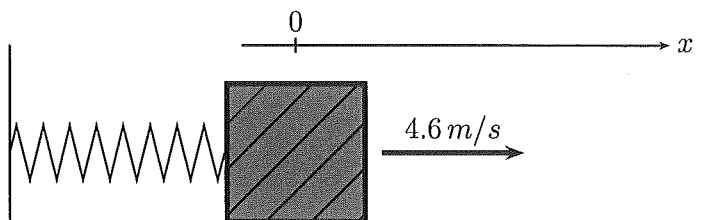

this one!

(a)	$-\frac{\pi}{2}$
(b)	$\frac{\pi}{2}$
(c)	$-\frac{2\pi}{5}$
(d)	$\frac{2\pi}{5}$
(e)	0

$$x = A \cos(\omega t + \phi) \Rightarrow x_0 = A \cos \phi$$

$$x_0 = 0 \Rightarrow A \cos \phi = 0 \Rightarrow \phi = \pm \pi/2$$

$$v = \frac{dx}{dt} = -\omega A \sin(\omega t + \phi)$$

$$\Rightarrow v_0 = -\omega A \sin \phi$$

$v_0 = +4.6 \text{ m/s} \Rightarrow$ positive so ϕ must be $-\pi/2$ such that

$$v_0 = -\omega A \sin(-\pi/2) = -\omega A (-1) = +\omega A$$

- (13.) On some alien planet, you find that a 0.34-m long simple pendulum has a period of 2.0 s, what is the acceleration due to gravity on that planet?

(a) 0.034 m/s^2
(b) 1.36 m/s^2
(c) 3.4 m/s^2
(d) 6.8 m/s^2
(e) 11 m/s^2

Simple Pendulum : $\omega = \sqrt{\frac{g}{L}}$

$$T = \frac{2\pi}{\omega} = 2\pi \sqrt{\frac{L}{g}}$$

$$\Rightarrow T^2 = \frac{4\pi^2 L}{g} \Rightarrow g = \frac{4\pi^2 L}{T^2}$$

$$\Rightarrow g = \frac{4\pi^2 (0.34 \text{ m})}{(2 \text{ s})^2} = 3.3557 \text{ m/s}^2 \\ = 3.4 \text{ m/s}^2$$

(14.) Which pair of graphs shown below correspond to a sinusoidal wave with a speed of $v = 0.8 \text{ cm/s}$?

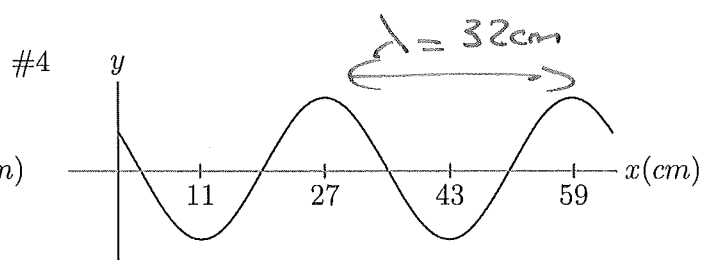
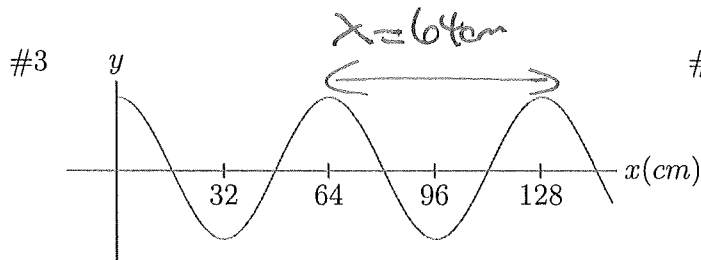
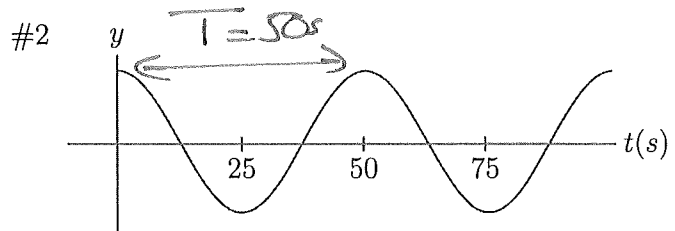
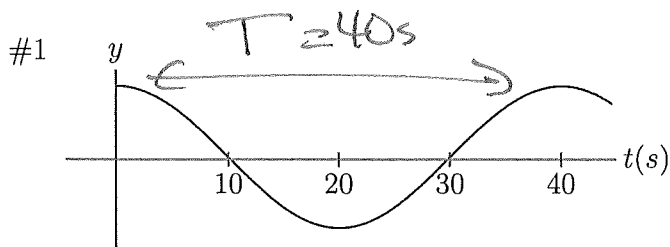

Nothing!

- | |
|---|
| (a) Graphs #2 and #1. |
| (b) Graphs #3 and #1. |
| <input checked="" type="checkbox"/> (c) Graphs #4 and #1. |
| (d) Graphs #3 and #2. |
| (e) Graphs #4 and #2. |

#1 AND #2 ARE
 y vs $t \Rightarrow$ Give Period

#3 AND #4 ARE y vs x
 \Rightarrow Give Wavelength

$$V = \frac{\lambda}{T} \Rightarrow V_{31} = \frac{64 \text{ cm}}{40 \text{ s}} = 1.6 \text{ cm/s}, \quad V_{41} = \frac{32 \text{ cm}}{40 \text{ s}} = 0.8 \text{ cm/s}$$

$$V_{32} = \frac{64 \text{ cm}}{50 \text{ s}} = 1.28 \text{ cm/s}, \quad V_{42} = \frac{32 \text{ cm}}{50 \text{ s}} = 0.64 \text{ cm/s}$$

- (15.) Your starship, *The Aimless Wanderer*, is in circular orbit around a 4.0×10^5 -m radius, alien planet (which by law you have to call Mongo) with a period of 3.0 hours. If *The Aimless Wanderer's* distance from the center of Mongo is 1.5×10^6 m, what is the acceleration due to gravity on the surface of planet Mongo? ^{1.45}

$$g = \frac{GM_p}{R_p^2}$$

$$R_p = 4 \times 10^5 \text{ m} \quad \text{but need Mongo's MASS}$$

$$T = \frac{2\pi r^{3/2}}{\sqrt{GM_p}} \quad \text{will provide mass}$$

$$r = 1.5 \times 10^6$$

$$T = 3 \text{ h} \times \frac{3600 \text{ s}}{\text{h}} = 10800 \text{ s}$$

$$T^2 = \frac{4\pi^2 r^3}{GM_p} \Rightarrow M_p = \frac{4\pi^2 r^3}{G T^2} = \frac{4\pi^2 (1.5 \times 10^6 \text{ m})^3}{(6.67 \times 10^{-11} \frac{\text{N}\cdot\text{m}^2}{\text{kg}^2}) (10800 \text{ s})^2} = 1.547 \times 10^{22} \text{ kg}$$

$$g = \frac{GM_p}{R_p^2} = \frac{(6.67 \times 10^{-11} \frac{\text{N}\cdot\text{m}^2}{\text{kg}^2}) (1.547 \times 10^{22} \text{ kg})}{(4 \times 10^5 \text{ m})^2} = \frac{6.449 \text{ m/s}^2}{\cancel{1.1 \times 10^2}} = 6.5 \text{ m/s}^2$$