

Green

- (1.) A 2000-kg tanker car going 5 m/s to the right collides with a 1200-kg boxcar going 7 m/s to the left. If they stick to each other after the collision, how fast and in what direction will they be going the instant after their collision?

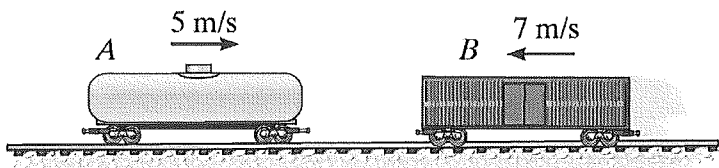

(a) 0.14 m/s to the left

(b) 0.5 m/s to the right

(c) 2 m/s to the left

(d) 5.75 m/s to the right

(e) 5.83 m/s to the right

AD  
^

Completely - Inelastic Collision :

$$M_A V_{A1,x} + M_B V_{B1,x} = (M_A + M_B) V_{2,x}$$

$$\Rightarrow (2000 \text{ kg})(5 \text{ m/s}) + (1200 \text{ kg})(-7 \text{ m/s}) = (3200 \text{ kg}) V_{2,x}$$

$$\Rightarrow V_{2,x} = \frac{1600 \text{ kg} \cdot \text{m/s}}{3200 \text{ kg}} = 0.5 \text{ m/s}$$

= 0.5 m/s to Right

(2.) What is the linear speed of a point  $0.75\text{ m}$  from the center of a wheel that is spinning at  $25\text{ RPM}$ ?

(a) $18.75\text{ m/s}$	(b) $12.5\text{ m/s}$	(c) $3.49\text{ m/s}$	(d) $1.96\text{ m/s}$	(e) $1.31\text{ m/s}$
------------------------	-----------------------	-----------------------	-----------------------	-----------------------

$V = \omega r$  but have to use rad/s

$$\omega = \frac{25\text{ rev}}{\text{min}} \times \frac{2\pi\text{ rad}}{\text{rev}} \times \frac{\text{min}}{60\text{ s}} = 2.618\text{ rad/s}$$

$$V = (2.618\text{ rad/s})(0.75\text{ m}) = 1.96\text{ m/s}$$

↑  
inconsistent

- (3.) A string is wrapped around a flywheel and attached to a large hook as shown. When released from rest, the hook falls down to the floor (with an increasing speed) causing the flywheel to rotate clockwise. What direction is the flywheel's angular acceleration?

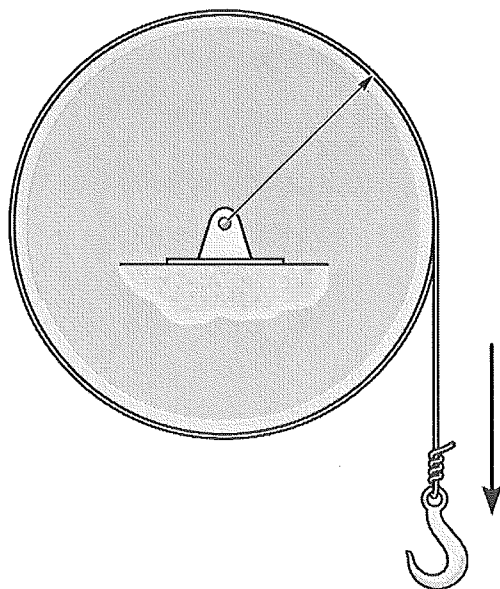

(a) $\otimes$
(b) $\odot$
(c) Up
(d) Down
(e) It has infinitely many directions.

Flywheel Rotating clockwise, so RHR  $\Rightarrow \vec{\omega}$  is  $\otimes$   
Hook increasing speed so  $\omega$  is also increasing

$\Rightarrow \vec{\alpha}$  is  $\otimes$  too

- (4.) A uniform thin rod of length  $l = 2.00\text{ m}$  is free to rotate about one end with no friction. If it is horizontal when released from rest, what angular speed will it have at the  $\theta = 30^\circ$  angle shown below? The moment of inertia for a thin rod rotated about one end is  $I = \frac{1}{3}Ml^2$ .

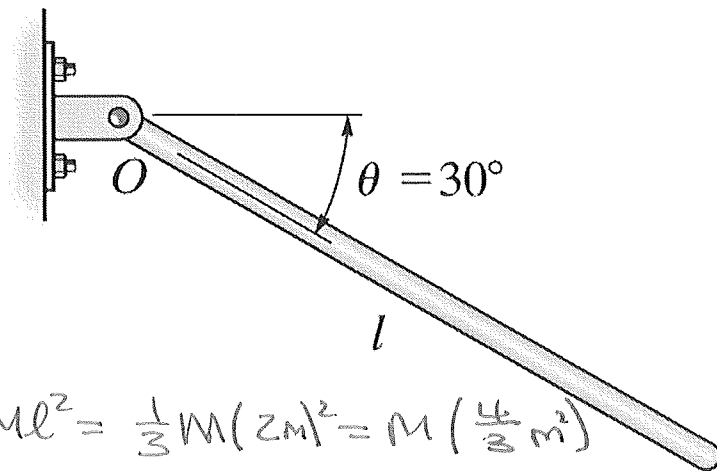

(a) 2.21 rad/s
(b) 2.71 rad/s
(c) 3.13 rad/s
(d) 3.83 rad/s
(e) 4.43 rad/s

$$I = \frac{1}{3}Ml^2 = \frac{1}{3}M(2\text{m})^2 = M\left(\frac{4}{3}\text{m}^2\right)$$

No friction  $\Rightarrow$  Gravity only force doing work

$$\text{Rotating} \Rightarrow \frac{1}{2}I\omega_1^2 + mgy_1 = \frac{1}{2}I\omega_2^2 + mgy_2$$

$y_1$  &  $y_2$  = Center of gravity's height. On form rod  $\Rightarrow \frac{l}{2} = 1\text{m}$

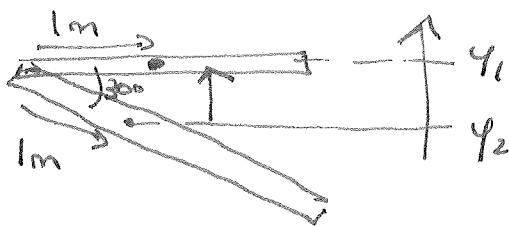

$$y_1 = 0.5\text{m}$$

$$y_2 = 0$$

$$\therefore M(9.8\text{m/s}^2)(0.5\text{m}) = \frac{1}{2}M\left(\frac{4}{3}\text{m}^2\right)\omega_2^2$$

$$\frac{1}{2}\omega_2 = \sqrt{\frac{2(9.8\text{m/s}^2)(0.5\text{m})}{\frac{4}{3}\text{m}^2}} = \sqrt{7.35/\text{s}^2} = 2.71\text{ rad/s}$$

- (5.) Two gears,  $B$  and  $D$ , are welded together and mounted on frictionless axle through their common center. A rope is wound around the edge of gear  $D$ . The other end of the rope is attached to a mass  $C$  which is free to fall towards the floor. Another gear  $A$  is in contact with  $B$  at its edge. If at the instant shown, the falling of mass  $C$  is causing gear  $D$  to rotate at  $30 \text{ RPM}$ , what is the angular speed of gear  $A$ ?

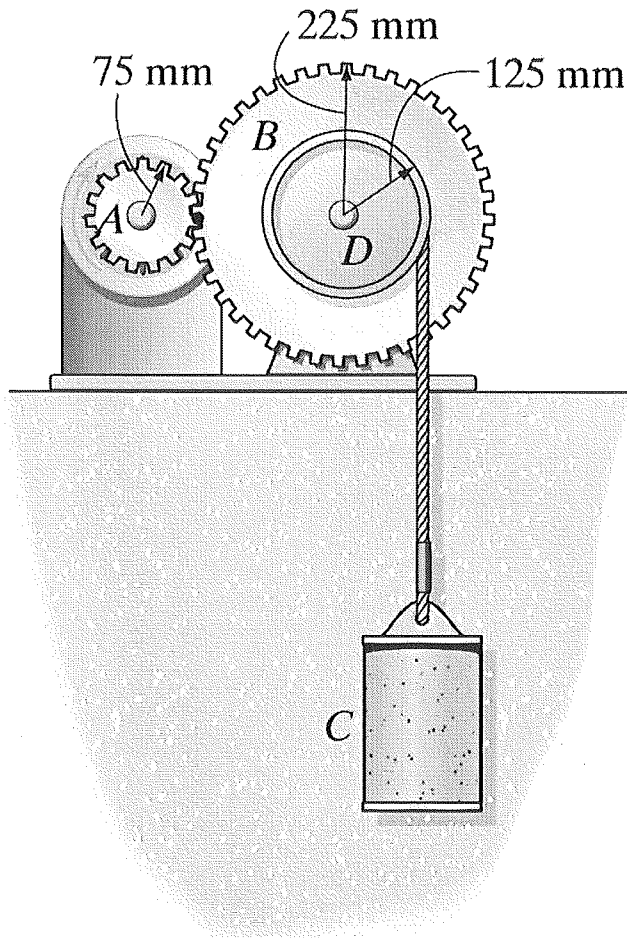

(a) 10 RPM
(b) 15 RPM
(c) 30 RPM
(d) 45 RPM
(e) 90 RPM

$B$  and  $D$  ~~must~~ <sup>must</sup> have same angular velocity  $\Rightarrow \omega_B = 30 \text{ RPM}$

$A$  &  $B$  must have same linear velocity  $\Rightarrow \omega_A r_A = \omega_B r_B$

$$\begin{aligned} \Rightarrow \omega_A (75 \text{ mm}) &= (30 \text{ RPM})(225 \text{ mm}) \Rightarrow \omega_A = 30 \text{ RPM} \left( \frac{225}{75} \right) = 30 \text{ RPM}(3) \\ &= 90 \text{ RPM} \end{aligned}$$

- (6.) A hollow sphere rotated about its center has moment of Inertia,  $I = \frac{2}{3}MR^2$ . Which of the following expressions is the correct one for the kinetic energy of a hollow sphere that is rolling without slipping?

(a) $\frac{1}{3}Mv^2$	(b) $\frac{1}{2}Mv^2$	(c) $\frac{2}{3}Mv^2$	(d) $\frac{5}{6}Mv^2$	(e) $\frac{5}{3}Mv^2$
-----------------------	-----------------------	-----------------------	-----------------------	-----------------------

$$\text{Rolling without slipping} \Rightarrow K = \frac{1}{2}Mv^2 \left( 1 + \frac{I}{MR^2} \right)$$

$$= \frac{1}{2}Mv^2 \left( 1 + \frac{\frac{2}{3}MR^2}{MR^2} \right) = \frac{1}{2}Mv^2 \left( 1 + \frac{2}{3} \right) = \frac{1}{2}Mv^2 \left( \frac{5}{3} \right)$$

$$= \frac{5}{6}Mv^2$$

- (7.) Shown below is a vaguely realistic model for the arm and bicep holding a can. The bicep is treated as a rope that pulls at an angle, which for a horizontal arm is  $75^\circ$ . Using this model, find how much force the bicep would have to exert in order to make the net torque about the elbow (point  $B$ ) zero. Assume the hand is holding a 2.5-kg can while the arm itself has a mass of 4.0 kg. Note: the points  $G_1$  and  $G_2$  specify the center of gravity of the can and the arm respectively.

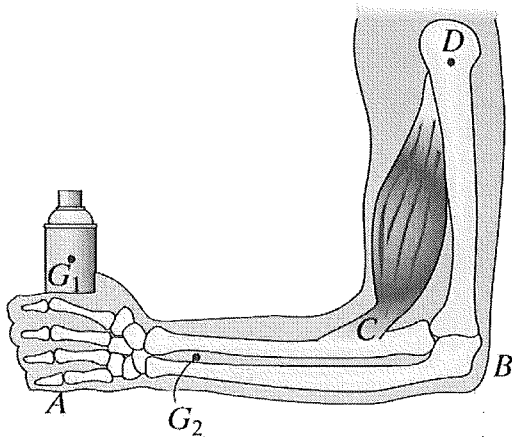

(a) 281 N
(b) 265 N
(c) 242 N
(d) 132 N
(e) 65.9 N

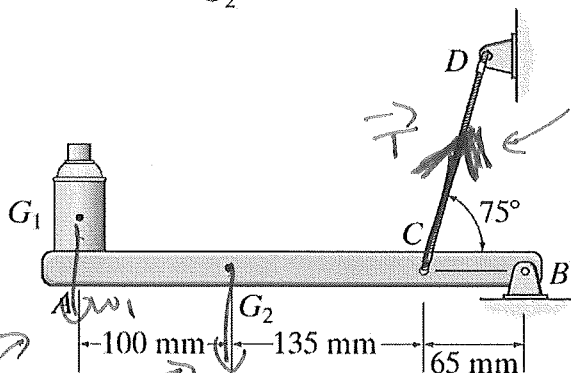

$$\sum \tau = 0 \Rightarrow \tau_{w_1} + \tau_{w_2} - \tau_T = 0$$

$$\Rightarrow \tau_T = \tau_{w_1} + \tau_{w_2}$$

$$\tau_{w_1} = x_1 M_1 g = (0.3 \text{ m})(2.5 \text{ kg})(9.8 \text{ m/s}^2) = 7.35 \text{ N}\cdot\text{m}$$

$$\tau_{w_2} = x_2 M_2 g = (0.2 \text{ m})(4 \text{ kg})(9.8 \text{ m/s}^2) = 7.84 \text{ N}\cdot\text{m}$$

Perpendicular component of  $T$

$$\tau_T = r T \sin 75^\circ = 0.065 \text{ m } T \sin 75^\circ$$

$$\therefore (0.065 \text{ m}) T \sin 75^\circ = 7.35 \text{ N}\cdot\text{m} + 7.84 \text{ N}\cdot\text{m} = 15.19 \text{ N}\cdot\text{m} \Rightarrow T = \frac{15.19 \text{ N}\cdot\text{m}}{(0.065 \text{ m}) \sin 75^\circ} =$$

242 N

- (8.) Stanley is standing on the edge of a merry-go-round that is rotating about its center with angular speed  $\omega$ . If Stanley walks toward the center of the merry-go-round without slipping, which of the following will happen? **Hint:** ~~The moment of inertia of the particle-like Stanley is given by  $Mr^2$~~

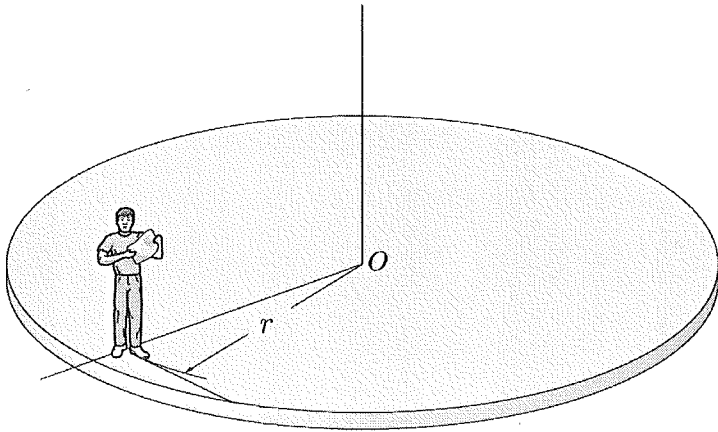

(a) $\omega$ will increase
(b) $\omega$ will decrease
(c) $\omega$ will stay the same
(d) There is not enough information to determine

CONSERVATION OF ANG. MOMENTUM:  $L_{TOTAL} = L_{MGR} + L_{Stanley} = \text{Constant}$

Stanley = particle  $\Rightarrow L_{Stanley} = mvr$

So as his  $r$  decreases so does his Angular Momentum.

$\Rightarrow$  Merry-go-rounds Angular Momentum MUST INCREASE

$\Rightarrow$  SPINS FASTER



- (9.) Two cars,  $M_A = 1500 \text{ kg}$  and  $M_B = 2000 \text{ kg}$ , have a collision at the intersection of Central and University. Before the collision, car A was going east on Central while car B south on University. Measurements taken at the scene of the accident indicate that after the collision car A was going  $10.6 \text{ m/s}$  at the  $40^\circ$  angle shown. If car B was going  $7.0 \text{ m/s}$  at  $30^\circ$ , was either of the cars speeding before their collision? The speed limit on Central is  $30 \text{ mph} = 13.4 \text{ m/s}$ . For full points, your answer must include a correct numerical calculation.

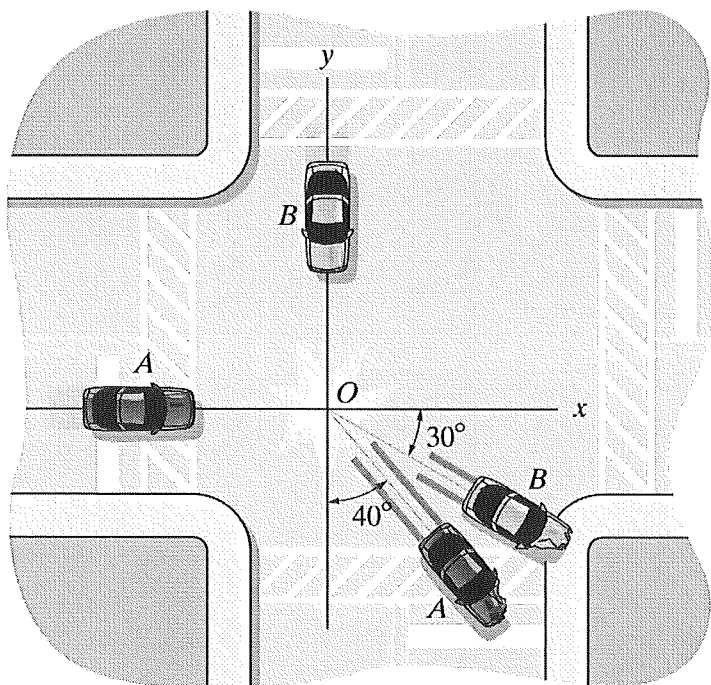

CONSERVATION OF MOMENTUM:

$$M_A V_{A1,x} + M_B V_{B1,x} = M_A V_{A2,x} + M_B V_{B2,x}$$

$$M_A V_{A1,y} + M_B V_{B1,y} = M_A V_{A2,y} + M_B V_{B2,y}$$

$$V_{A1,x} = V_{A1} = ? , V_{A1,y} = 0$$

$$V_{B1,x} = 0 , V_{B1,y} = -V_{B1} = ?$$

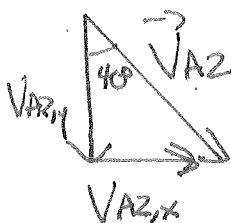

$$V_{A2,x} = V_{A2} \sin 40^\circ \leftarrow \text{NON-STANDARD}$$

$$V_{A2,y} = -V_{A2} \cos 40^\circ \leftarrow \text{STANDARD}$$

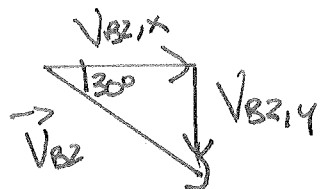

$$V_{B2,x} = V_{B2} \cos 30^\circ$$

$$V_{B2,y} = -V_{B2} \sin 30^\circ$$

X-Comp:  $1500 \text{ kg } V_{A1} = 1500 \text{ kg } (10.6 \text{ m/s}) \sin 40^\circ + 2000 \text{ kg } (7 \text{ m/s}) \cos 30^\circ = 22345 \text{ kg} \cdot \text{m/s}$

$$\Rightarrow V_{A1} = \frac{22345 \text{ kg} \cdot \text{m/s}}{1500 \text{ kg}} = \underline{\underline{14.9 \text{ m/s}}}$$

y-Comp:  $2000 \text{ kg } (-V_{B1}) = 1500 \text{ kg } (-10.6 \text{ m/s}) \cos 40^\circ + 2000 \text{ kg } (-7 \text{ m/s}) \sin 30^\circ = -19180 \text{ kg} \cdot \text{m/s}$

$$\Rightarrow V_{B1} = \frac{-19180 \text{ kg} \cdot \text{m/s}}{2000 \text{ kg}} = \underline{\underline{9.59 \text{ m/s}}}$$

A WAS speeding. B WAS NOT