

1. A $M_A = 5 \text{ kg}$ mass with $\vec{v}_{A1} = 25 \text{ m/s}$ at 32° (relative to the $+x$ -axis) collides with a stationary $M_B = 15 \text{ kg}$ mass. If M_B bounces to the right with a speed of 8 m/s , with what speed does M_A bounce?

(a) 13.54 m/s	(b) 20.8 m/s	(c) 25 m/s	(d) 8 m/s
-------------------------	------------------------	----------------------	---------------------

2. Using the information from the previous problem, at what angle does M_A bounce? Note: All answers are given relative to the positive x -axis

(a) 180°	(b) 102°	(c) -78°	(d) Cannot be determined.
-----------------	-----------------	-----------------	---------------------------

3. A $M_A = 5 \text{ kg}$ mass with $v_{A1} = 6 \text{ m/s}$ and a $M_B = 7 \text{ kg}$ mass with $v_{B1} = 2 \text{ m/s}$ have an elastic collision. If $v_{A2} = 3 \text{ m/s}$, v_{B2} has what value?

(a) 1 m/s	(b) 4 m/s	(c) 4.83 m/s	(d) 4.14 m/s
---------------------	---------------------	------------------------	------------------------

4. A $M_A = 5 \text{ kg}$ mass with $\vec{v}_{A1} = 6 \text{ m/s}$ at 32° and a $M_B = 3 \text{ kg}$ with $\vec{v}_{B1} = 2 \text{ m/s}$ at 175° have a two-dimensional elastic collision. What \vec{v}_{A2} and \vec{v}_{B2} make the collision elastic?

(a) $\vec{v}_{A2} = 4 \text{ m/s}$ at 122° , $\vec{v}_{B2} = 6.11 \text{ m/s}$ at 32°
(b) $\vec{v}_{A2} = 4 \text{ m/s}$ at 122° , $\vec{v}_{B2} = 6.11 \text{ m/s}$ at 212°
(c) $\vec{v}_{A2} = 4 \text{ m/s}$ at 32° , $\vec{v}_{B2} = 6.11 \text{ m/s}$ at 122°
(d) There is not enough information to determine.

5. A 1.0 kg mass is lifted vertically two meters (on Earth) with a constant 2.3 m/s^2 acceleration. How much work is done by the lifting force, \vec{F} ?

(a) $W = 19.6 \text{ J}$	(b) $W = -19.6 \text{ J}$	(c) $W = 24.2 \text{ J}$	(d) $W = -24.2 \text{ J}$
--------------------------	---------------------------	--------------------------	---------------------------

6. An 80 kg man has an apparent weight of 1504 N at the bottom of a circular dip. If his speed is 6.0 m/s , what is the radius of the circle?

(a) $r = 9 \text{ m}$	(b) $r = 1.26 \text{ m}$	(c) $r = 4 \text{ m}$	(d) $r = 9.8 \text{ m}$
-----------------------	--------------------------	-----------------------	-------------------------

7. A 700 kg car is traveling with a speed of 30 m/s . If 5.2 s later, its speed is 19.6 m/s , how much work, in total, was done to the car? Note the use of $\text{kJ} = \text{kiloJoules}$ to make the numbers smaller.

(a) $W = 1770\text{ kJ}$	(b) $W = -35\text{ kJ}$	(c) $W = 9.8\text{ kJ}$	(d) $W = -180\text{ kJ}$
--------------------------	-------------------------	-------------------------	--------------------------

Work, Work, Work

Émilie du Châtelet drops a $.25\text{ kg}$ ball from rest, 1.6 m above a sand pit.

8. If the ball hits the sand going 3.2 m/s , how much work was done by air resistance during the ball's fall?

(a) 1.28 J	(b) -3.92 J	(c) -2.64 J	(d) -1.28 J
---------------------	----------------------	----------------------	----------------------

9. Ignoring gravity, how much work must the sand do in order to stop the 3.2 m/s ball?

(a) 1.28 J	(b) -3.92 J	(c) -2.64 J	(d) -1.28 J
---------------------	----------------------	----------------------	----------------------

10. If the force exerted by the sand increases linearly with depth below the sand, as shown on the graph below ($y = 0$ is at the top of the sand pit and down is positive), how far will the ball sink below the surface before stopping? Again, ignore gravity in this calculation.

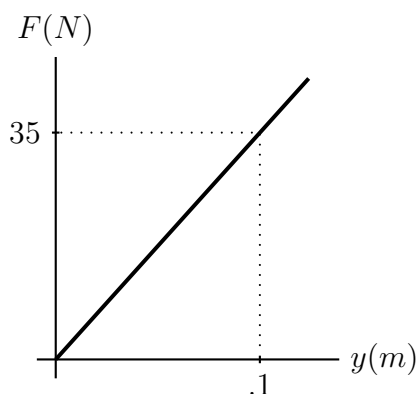

- | | | | |
|------------|------------|------------|------------|
| (a) .037 m | (b) .191 m | (c) .086 m | (d) .060 m |
|------------|------------|------------|------------|

11. If the sand provides 24 *Watt* of average power, estimate the time it takes for the ball to stop.

- | | | | |
|------------|------------|-----------|---------|
| (a) .053 s | (b) .025 s | (c) 9.8 s | (d) 3 s |
|------------|------------|-----------|---------|

12. If we were to include the effect of gravity in the previous calculation, the ball would:

- | | |
|-------------------------------------|---|
| (a) go deeper into the sand. | (b) go the same distance into the sand. |
| (c) go less distance into the sand. | (d) bounce off the sand. |

Sliding

A 5.6 kg box is sitting stationary on a frictionless surface when your instructor steps up to it and applies, in the positive x direction, a non-constant force, F .

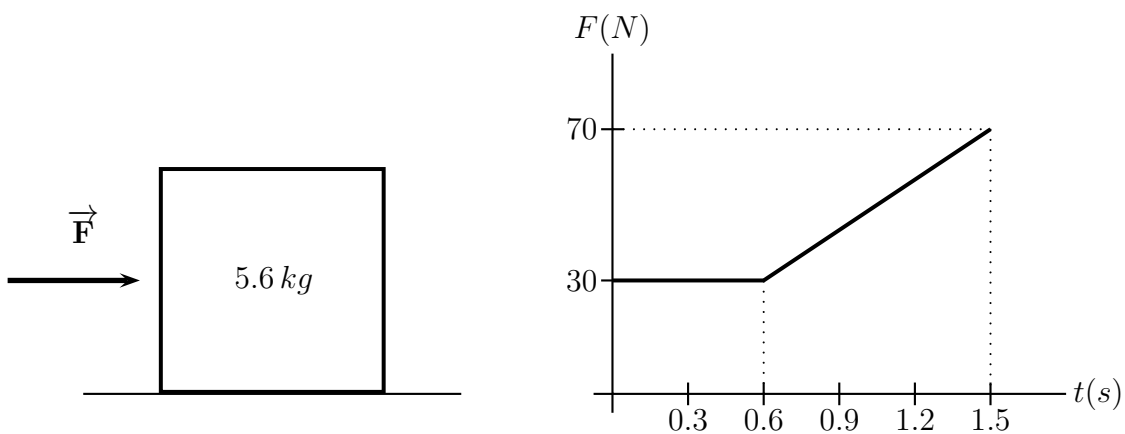

13. What impulse was imparted to the mass by your instructor's force?

(a) $45\text{ N} \cdot \text{s}$	(b) $105\text{ N} \cdot \text{s}$	(c) $18\text{ N} \cdot \text{s}$	(d) $63\text{ N} \cdot \text{s}$
----------------------------------	-----------------------------------	----------------------------------	----------------------------------

14. What was the average force exerted on the mass?

(a) 30 N	(b) 42 N	(c) 50 N	(d) 70 N
-------------------	-------------------	-------------------	-------------------

15. How fast was the 5.6 kg , initially at rest, mass going after 1.5 s ?

(a) 11.25 m/s	(b) 353 m/s	(c) 4.74 m/s	(d) 22.5 m/s
------------------------	----------------------	-----------------------	-----------------------

16. After being pushed, the 5.6 kg box slides across the frictionless floor and collides with a 9.0 kg lump of clay that is traveling in the opposite direction. If the box and the clay stick to each other and have a post-collision velocity of 0.5 m/s to the right, how fast was the clay going the instant before the collision?

(a) 7.3 m/s	(b) 9 m/s	(c) 6.2 m/s	(d) 56 m/s
----------------------	--------------------	----------------------	---------------------

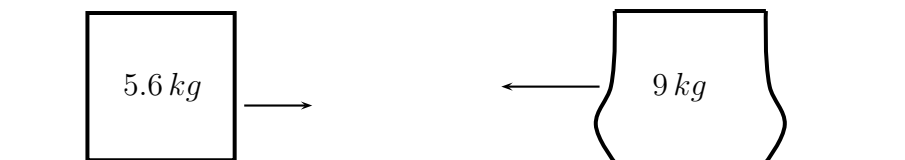

17. How much heat was produced during this collision?

(a) 354 J	(b) 1.825 J	(c) 172 J	(d) 525 J
--------------------	----------------------	--------------------	--------------------

Lifting

One day finds your instructor needing to lift a 10.0 kg box. As usual, he has completely over-complicated the procedure by using a massless pulley and a motor as shown below. Your instructor observes that when the motor has lifted the box 4.0 m above the floor, it has a speed of 5.0 m/s .

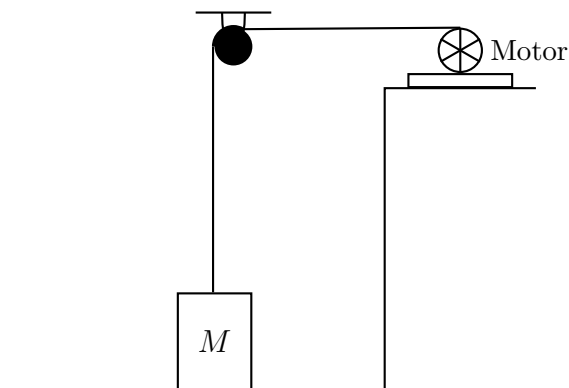

18. How much gravitational potential energy does the box have? (Assume the on the floor, the box had zero potential energy.)

(a) 98 J	(b) 4 J	(c) 392 J	(d) 400 J
-------------------	------------------	--------------------	--------------------

19. How much kinetic energy does the box have?

(a) 250 J	(b) 392 J	(c) 517 J	(d) 125 J
--------------------	--------------------	--------------------	--------------------

20. Assuming the box started from rest, how much work was done by the motor lifting the box to 4 m ?

(a) 267 J	(b) 392 J	(c) 517 J	(d) 125 J
--------------------	--------------------	--------------------	--------------------

21. If at the instant the box is 4 m above the ground the motor is supplying 640 Watt of power, what is the box's acceleration? **HINT:** Use the equation $P = \vec{\mathbf{F}} \cdot \vec{\mathbf{v}}$ where $\vec{\mathbf{F}}$ is the force the motor exerts on the rope and $\vec{\mathbf{v}}$ is the velocity of the rope entering the motor.

(a) 9.8 m/s^2	(b) 0 m/s^2	(c) 128 m/s^2	(d) 3 m/s^2
------------------------	----------------------	------------------------	----------------------

22. Assuming constant acceleration, which of the following is a true statement about the average power, P_{av} supplied by the motor while the box was rising 4 m ?

(a) $P_{av} = 640\text{ Watt}$	(b) $P_{av} > 640\text{ Watt}$
(c) $P_{av} < 640\text{ Watt}$	(d) There is not enough information to determine.

23. High Art

One day whilst on a walking tour of Santa Fe, you come across a most curious piece of kinetic art. It consists of an 18 kg steel collar that vertically slides over a frictionless, fancy-shaped track while attached to a 26 N/m spring. As shown below, the spring, unstretched length 1.1 m , is connected so that it is free to swing around with the mass and is always oriented along the line connecting the collar and the point labeled O .

The *artiste* who designed the sculpture proudly tells you that she has carefully designed the track so that it has the famous shape called a limaçon. She's even able to give you the exact equation for the track's limaçon, $r = (5 + \cos \theta)$, where r is the distance (in meters) from O to the collar and θ is the angle shown below.

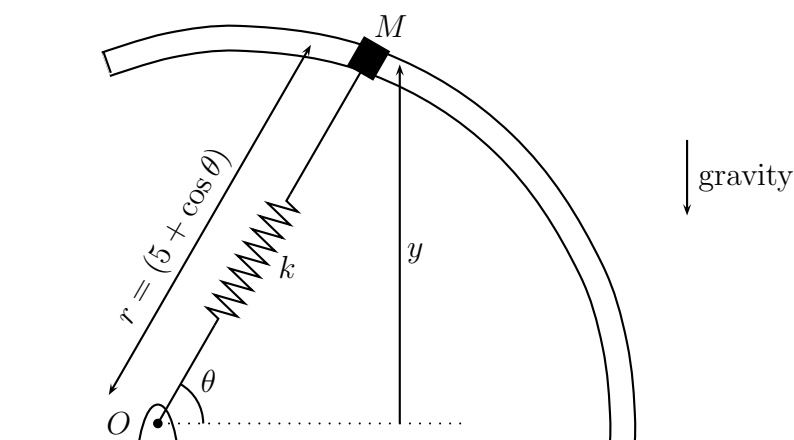

- (a) The *artiste* informs you that her original vision had the 18 kg collar starting from rest at $\theta = 90^\circ$ and gracefully sliding down to $\theta = 0^\circ$. She was “bummed” (to use her phrase) when the collar did no such thing. It had to be started with some minimum speed. Using methods discussed in the bonus, you find that the

collar's potential energy is greatest at $\theta = 73.4^\circ$. What minimum speed must be given to the collar at $\theta = 90^\circ$ for it to just reach $\theta = 73.4^\circ$? **HINT:** The mass has potential energy due to gravity and the spring. The picture indicates how to find the height, y , of the mass for any angle θ . The stretching distance of the spring is given by $r - l_0$ where l_0 is the spring's unstretched length.

(b) During one particularly memorable run of the sculpture, the collar went from $\theta = 73.4^\circ$ (where it was momentarily at rest) down to $\theta = 0^\circ$ whilst a big gust of wind was blowing. (It was so impressive that your monocle nearly popped out.) If the collar reached $\theta = 0^\circ$ with a speed of 6.5 m/s , how much work was done by that gust of wind?

(c) **BONUS:** Show that the potential energy of the collar has its maximum value at the point where $\theta = 73.4^\circ$. **HINT:** Find the potential energy as a function of theta. Use your new/old-found calculus skills to find the maximum.

24. The Great Glass Elevator

One day finds little Charlie Bucket (mass 48 kg) and Willy Wonka riding around (on Earth) in their fabulous great glass elevator. If you've never read the book, the great glass elevator is an elevator that can move in any direction you might wish. Sometime during their trip, little Charlie Bucket and Willy Wonka turn a corner in the great glass elevator by zooming around a 100 m radius circle with a speed of 22.2 m/s . For reasons that only make sense to Willy Wonka (and your instructor), Charlie is riding in the elevator standing on a scale.

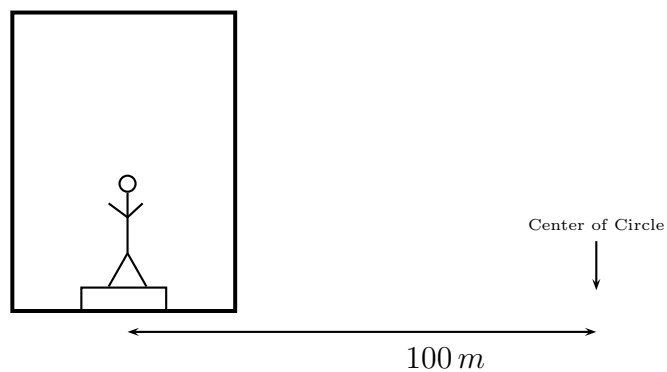

- (a) If the coefficient of static friction between Charlie Bucket and his scale is $.39$, will he be able to remain not-sliding as he travels around this circle? Assume, as shown above, that the center of the circle is directly to the right of Charlie Bucket. (You must do a calculation of some sort to get full credit on this problem)

- (b) By fiddling with some buttons, Willy Wonka discovers that he can tilt the great glass elevator to any angle that he wishes. To what angle θ should Willy Wonka tilt the elevator so that no friction is necessary for Charlie Bucket to go around a 100 m radius circle (whose center is still directly to his right) with a speed of 22.2 m/s ? What would the scale read in this case?

