

①

1. Motion on a sphere $F_\theta = mR(\ddot{\theta} - \dot{\phi}^2 \sin\theta \cos\theta)$
 $F_\phi = mR(2\dot{\theta}\dot{\phi} \cos\theta + \ddot{\phi} \sin\theta)$

Motion south at $100 \frac{\text{km}}{\text{h}}$

$$\dot{\phi} = \text{Earth's rotation} = \frac{2\pi}{\text{day}} \cdot \frac{\text{day}}{24\text{h}} \cdot \frac{\text{h}}{3600\text{s}} = 7.27 \times 10^{-5} \text{ s}^{-1}$$

$$\ddot{\phi} = 0$$

$$\theta = 90^\circ - 35^\circ \leftarrow \text{abg latitude} = 55^\circ \quad \sin\theta = 0.82$$

$$\cos\theta = 0.57$$

$$\dot{\theta} = \frac{v}{R} = \frac{100 \frac{\text{km}}{\text{h}}}{6366 \text{ km}} \times \frac{\text{h}}{3600 \text{ s}} = 4.36 \times 10^{-6} \text{ s}^{-1}$$

$$\ddot{\theta} = 0$$

$$F_\theta = 1000 \text{ kg} \cdot 6.366 \times 10^6 \text{ m} \left[-\left(7.27 \times 10^{-5}\right)^2 \cdot 0.82 \cdot 0.57 \right] = -15.6 \text{ N}$$

NS Force on car is 15.6 N north. (This counters centrifugal force!)

$$F_\phi = 1000 \text{ kg} \cdot 6.366 \times 10^6 \text{ m} \left[2 \cdot 7.27 \times 10^{-5} \cdot 4.36 \times 10^{-6} \cdot 0.57 \right] = 2.3 \text{ N}$$

EW force on car is 2.3 N $\hat{\phi}$, which is eastward.

Traveling East at 100 km/h

$$\dot{\theta} = \ddot{\theta} = 0, \quad \dot{\phi} = \dot{\phi}_{\text{earth}} + \dot{\phi}_{\text{car}} = 7.71 \times 10^{-5} \text{ s}^{-1}, \quad \ddot{\phi} = 0$$

$$F_\theta = 1000 \text{ kg} \cdot 6.366 \times 10^6 \text{ m} \left[-\left(7.71 \times 10^{-5}\right)^2 \cdot 0.82 \cdot 0.57 \right] = -17.7 \text{ N}$$

$$F_\phi = 0 \text{ because } \dot{\theta} = 0 \text{ and } \ddot{\phi} = 0$$

At equator, $\theta = 90^\circ$ $\cos\theta = 0$.

$$\ddot{\phi} = 0 \text{ so } F_\phi = 0, \quad \ddot{\theta} = 0 \text{ so } F_\theta = 0$$

It's almost an inertial frame! (Motion along \hat{r} is non-inertial,)

2.a)

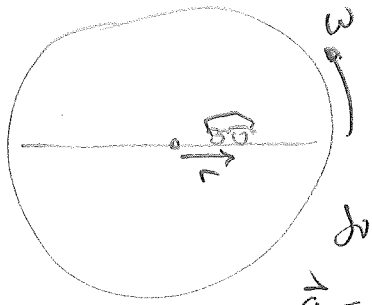

Note that: $v_r \equiv \frac{dr}{dt} = at$ $\theta = \omega t$

$$r = \frac{1}{2}at^2 \quad \dot{\theta} = \omega$$

$$\ddot{\theta} = 0$$

$$\vec{a} = (\ddot{r} - r\dot{\theta}^2)\hat{r} + (r\ddot{\theta} + 2\dot{r}\dot{\theta})\hat{\theta}$$

$$= (a - \frac{1}{2}at^2 \cdot \omega^2)\hat{r} + (\frac{1}{2}at^2 \cdot 0 + 2at \cdot \omega)\hat{\theta}$$

The acceleration is caused by the frictional force.

$$\vec{F}_c = m\vec{a} \quad \text{so} \quad |\vec{a}| \leq \mu g \quad \text{or} \quad \vec{a} \cdot \vec{a} \leq \mu^2 g^2$$

$$|\vec{F}_f| \leq \mu mg$$

$$a^2 - a^2 \omega^2 t^2 + \frac{1}{4}a^2 \omega^4 t^4 + 4a^2 \omega^2 t^2 \leq \mu^2 g^2$$

Let $u = (\omega t)^2$, $\gamma = \mu g / a$.

$$1 - 3u + \frac{1}{4}u^2 \leq \gamma^2$$

(solve for =)

$$u^2 + 12u + 4(1 - \gamma^2) = 0$$

$$u = \frac{-12 \pm \sqrt{144 - 16(1 - \gamma^2)}}{2}$$

Need + root for $u > 0$.

$$u = -6 + \sqrt{32 + 4\gamma^2}$$

$$\boxed{\omega t = \sqrt{\sqrt{32 + 4\gamma^2} - 6}}$$

Numbers: $\mu = 0.4$, $g = 10 \text{ m/s}^2$, $a = 1 \text{ m/s}^2$

$$\gamma = 4. \quad \text{so}$$

$$\omega t = 1.949. \quad \text{with } \omega = 1.5, \quad t = 1.299 \text{ s.}$$

b) Assuming g stays the same, γ stays same.

$$\omega t \text{ is still } 1.949, \text{ but } \omega = 2 \text{ s}^{-1} \text{ so } t = \text{half as big} = 0.974 \text{ s.}$$

(3)

c) Place where it slips in part a

$$r = \frac{1}{2} a t^2 = 1.9 \text{ m.}$$

$$\theta = \omega b = 1.95^\circ \text{ rad.}$$

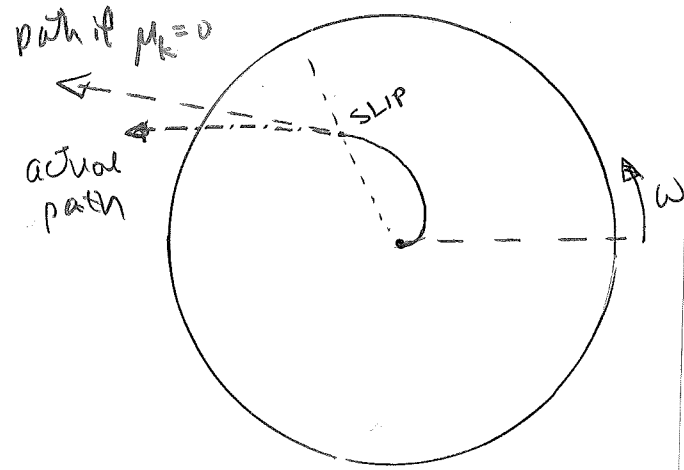

$$3. \quad F = -cV^{3/2} = \frac{dV}{dt} \quad \int \frac{dV}{V^{3/2}} = \int -c dt \quad V^{-1/2} = -ct + k \quad k = V_0^{-1/2}$$

$$V^{1/2} = \frac{1}{V_0^{-1/2} - ct} \quad V = \frac{1}{(V_0^{-1/2} - ct)^2} = \frac{dx}{dt} \quad (\text{as } t \rightarrow \infty, V \rightarrow 0)$$

$$\int \frac{dt}{(V_0^{-1/2} - ct)^2} = \int dx$$

$$= \frac{1}{c} \frac{1}{V_0^{-1/2} - ct} = x + k_2$$

$$\text{When } t=0, \quad -\frac{1}{c} V_0^{1/2} = x_0 + k \quad k = \frac{-V_0^{1/2}}{c} - x_0$$

$$\text{So } x = \frac{V_0^{1/2}}{c} + x_0 - \frac{1}{c} \frac{1}{V_0^{-1/2} - ct}$$

$$\text{As } t \rightarrow \infty \quad x \rightarrow x_0 + \frac{V_0^{1/2}}{c} \quad \text{Stopping distance} = \frac{V_0^{1/2}}{c}$$

It never stops (in time), but goes a finite distance.

4. Sprinkler problem.

Let's use only θ from 0° to 45° . ($45^\circ \rightarrow 90^\circ$ will water same area.)

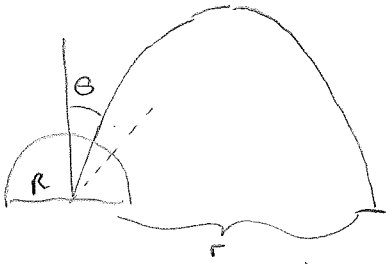

Density of holes at angle $\theta = p(\theta)$

Number of holes $dN = p(\theta) 2\pi R \sin\theta d\theta$.

This waters area $2\pi r dr$.

Holes per area watered = constant = $\frac{p(\theta) 2\pi R \sin\theta d\theta}{2\pi r dr}$

Range of a projectile $r = \frac{2v^2}{g} \cos\theta \sin\theta = \frac{v^2}{g} \sin 2\theta$

So

$$p(\theta) \propto \frac{r}{\sin\theta} \frac{dr}{d\theta} = \cos\theta \cdot \cos 2\theta.$$

$$5. a) F = ma = m \frac{dv}{dt} = -mg - bv \int \frac{dv}{g + \beta v} = \int -dt \quad \beta \equiv b/m$$

$$\frac{1}{\beta} \ln(g + \beta v) = -t + c$$

$$g + \beta v = c e^{-\beta t} \Rightarrow v = c e^{-\beta t} - g/\beta$$

$$v_t = g/\beta$$

$$\text{at } t=0, v=v_0 \quad v_0 = c - g/\beta = c - v_t. \quad c = v_0 + v_t$$

$$v = (v_0 + v_t) e^{-\beta t} - v_t = \frac{dy}{dt}$$

$$y + c = \int [(v_0 + v_t) e^{-\beta t} - v_t] dt$$

$$y + c = -\frac{1}{\beta} (v_0 + v_t) e^{-\beta t} - v_t t$$

$$\text{At } t=0, y=0, \text{ so } c = -\frac{1}{\beta} (v_0 + v_t). \quad y = \frac{1}{\beta} (v_0 + v_t) [1 - e^{-\beta t}] - v_t t$$

$$b) \text{ Highest point: } v=0 \quad (v_0 + v_t) e^{-\beta t} = v_t$$

$$e^{-\beta t} = \frac{v_t}{v_0 + v_t}$$

$$t = -\frac{1}{\beta} \ln\left(\frac{v_t}{v_0 + v_t}\right)$$

at top

$$y_{\text{top}} = \frac{1}{\beta} (v_0 + v_t) \cdot \left[1 - \frac{v_t}{v_0 + v_t}\right] + \frac{v_t}{\beta} \ln\left(\frac{v_t}{v_0 + v_t}\right)$$

$$= \frac{v_0}{\beta} + \frac{v_t}{\beta} \ln\left(\frac{v_t}{v_0 + v_t}\right) = \frac{v_0}{\beta} - \frac{v_t}{\beta} \ln\left(\frac{v_0 + v_t}{v_t}\right)$$

$$c) \text{ As } \beta \text{ gets small, } \frac{v_0}{v_t} \rightarrow 0 \text{ so } y_{\text{top}} = \frac{v_0}{\beta} - \frac{v_t}{\beta} \left(\frac{v_0}{v_t} - \frac{1}{2} \frac{v_0^2}{v_t^2}\right)$$

$$= + \frac{1}{2} \frac{v_0^2}{\beta v_t} = \frac{1}{2} \frac{v_0^2}{g}$$

2-11. The equation of motion is

$$m \frac{d^2x}{dt^2} = -kmv^2 + mg$$

This equation can be solved exactly in the same way as in problem 2-12 and we find

$$x = \frac{1}{2k} \log \left[\frac{g - kv_0^2}{g - kv^2} \right]$$

where the origin is taken to be the point at which $v = v_0$ so that the initial condition is $x(v = v_0) = 0$. Thus, the distance from the point $v = v_0$ to the point $v = v_1$ is

$$s(v_0 \rightarrow v_1) = \frac{1}{2k} \log \left[\frac{g - kv_0^2}{g - kv_1^2} \right]$$

2-12. The equation of motion for the upward motion is

$$m \frac{d^2x}{dt^2} = -mkv^2 - mg \quad (1)$$

Using the relation

$$\frac{d^2x}{dt^2} = \frac{dv}{dt} = \frac{dv}{dx} \frac{dx}{dt} = v \frac{dv}{dx} \quad (2)$$

we can rewrite (1) as

$$\frac{v dv}{kv^2 + g} = -dx \quad (3)$$

Integrating (3), we find

$$\frac{1}{2k} \log(kv^2 + g) = -x + C \quad (4)$$

where the constant C can be computed by using the initial condition that $v = v_0$ when $x = 0$:

$$C = \frac{1}{2k} \log(kv_0^2 + g) \quad (5)$$

Therefore,

$$x = \frac{1}{2k} \log \frac{kv_0^2 + g}{kv^2 + g} \quad (6)$$

Now, the equation of downward motion is

$$m \frac{d^2x}{dt^2} = -mkv^2 + mg \quad (7)$$

This can be rewritten as

$$\frac{v dv}{-kv^2 + g} = dx \quad (8)$$

Integrating (8) and using the initial condition that $x = 0$ at $v = 0$

$$x = \frac{1}{2k} \log \frac{g}{g - kv^2} \quad (9)$$

At the highest point the velocity of the particle must be zero.

substituting $v = 0$ in (6):

$$x_h = \frac{1}{2k} \log \frac{kv_0^2 + g}{g} \quad (10)$$

Then, substituting (10) into (9),

$$\frac{1}{2k} \log \frac{kv_0^2 + g}{g} = \frac{1}{2k} \log \frac{g}{g - kv^2} \quad (11)$$

Solving for v ,

$$v = \sqrt{\frac{\frac{g}{k} v_0^2}{v_0^2 + \frac{g}{k}}} \quad (12)$$

We can find the terminal velocity by putting $x \rightarrow \infty$ in (9). This gives

$$v_t = \sqrt{\frac{g}{k}} \quad (13)$$

Therefore,

$$v = \frac{v_0 v_t}{\sqrt{v_0^2 + v_t^2}} \quad (14)$$

2-14.

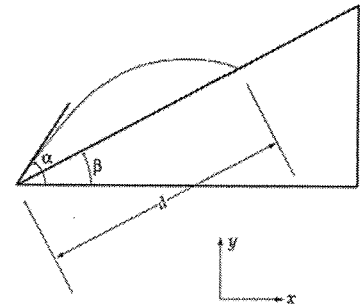

a) The equations for the projectile are

$$x = v_0 \cos \alpha t$$

$$y = v_0 \sin \alpha t - \frac{1}{2} g t^2$$

Solving the first for t and substituting into the second gives

$$y = x \tan \alpha - \frac{1}{2} \frac{g x^2}{v_0^2 \cos^2 \alpha}$$

Using $x = d \cos \beta$ and $y = d \sin \beta$ gives

$$d \sin \beta = d \cos \beta \tan \alpha - \frac{g d^2 \cos^2 \beta}{2 v_0^2 \cos^2 \alpha}$$

$$0 = d \left[\frac{g d \cos^2 \beta}{2 v_0^2 \cos^2 \alpha} - \cos \beta \tan \alpha + \sin \beta \right]$$

Since the root $d = 0$ is not of interest, we have

$$d = \frac{2(\cos \beta \tan \alpha - \sin \beta) v_0^2 \cos^2 \alpha}{g \cos^2 \beta}$$

$$= \frac{2 v_0^2 \cos \alpha (\sin \alpha \cos \beta - \cos \alpha \sin \beta)}{g \cos^2 \beta}$$

$$d = \frac{2 v_0^2 \cos \alpha \sin(\alpha - \beta)}{g \cos^2 \beta}$$

b) Maximize d with respect to α

$$\frac{d}{d\alpha}(d) = 0 = \frac{2v_0^2}{g \cos^2 \beta} [-\sin \alpha \sin(\alpha - \beta) + \cos \alpha \cos(\alpha - \beta)] \cos(2\alpha - \beta)$$

$$\cos(2\alpha - \beta) = 0$$

$$2\alpha - \beta = \frac{\pi}{2}$$

$$\boxed{\alpha = \frac{\pi}{4} + \frac{\beta}{2}}$$

c) Substitute (2) into (1)

$$d_{\max} = \frac{2v_0^2}{g \cos^2 \beta} \left[\cos\left(\frac{\pi}{4} + \frac{\beta}{2}\right) \sin\left(\frac{\pi}{4} - \frac{\beta}{2}\right) \right]$$

Using the identity

$$\sin A - \sin B = 2 \cos \frac{1}{2}(A+B) \sin \frac{1}{2}(A-B)$$

we have

$$d_{\max} = \frac{2v_0^2}{g \cos^2 \beta} \cdot \frac{\sin \frac{\pi}{2} - \sin \beta}{2} = \frac{v_0^2}{g} \left[\frac{1 - \sin \beta}{1 - \sin^2 \beta} \right]$$

$$\boxed{d_{\max} = \frac{v_0^2}{g(1 + \sin \beta)}}$$

2-19. The projectile's motion is described by

$$\left. \begin{aligned} x &= (v_0 \cos \alpha)t \\ y &= (v_0 \sin \alpha)t - \frac{1}{2}gt^2 \end{aligned} \right\} \quad (1)$$

where v_0 is the initial velocity. The distance from the point of projection is

$$r = \sqrt{x^2 + y^2} \quad (2)$$

Since r must always increase with time, we must have $\dot{r} > 0$:

$$\dot{r} = \frac{x\dot{x} + y\dot{y}}{r} > 0 \quad (3)$$

Using (1), we have

$$x\dot{x} + y\dot{y} = \frac{1}{2}g^2t^3 - \frac{3}{2}g(v_0 \sin \alpha)t^2 + v_0^2t \quad (4)$$

Let us now find the value of t which yields $x\dot{x} + y\dot{y} = 0$ (i.e., $\dot{r} = 0$):

$$t = \frac{3}{2} \frac{v_0 \sin \alpha}{g} \pm \frac{v_0}{2g} \sqrt{9 \sin^2 \alpha - 8} \quad (5)$$

For small values of α , the second term in (5) is imaginary. That is, $r = 0$ is never attained and the value of t resulting from the condition $\dot{r} = 0$ is unphysical.

Only for values of α greater than the value for which the radicand is zero does t become a physical time at which \dot{r} does in fact vanish. Therefore, the maximum value of α that insures $\dot{r} > 0$ for all values of t is obtained from

$$9 \sin^2 \alpha_{\max} - 8 = 0 \quad (6)$$

or,

$$\sin \alpha_{\max} = \frac{2\sqrt{2}}{3} \quad (7)$$

so that

$$\boxed{\alpha_{\max} \cong 70.5^\circ} \quad (8)$$